

KOMATSU®

WA600-6 With Tier 3 Engine

NET HORSEPOWER
393 kW **527 HP** @ 1800 rpm

OPERATING WEIGHT
53700 - 53900 kg
118,385 - 118,825 lb

BUCKET CAPACITY
6.4 - 7.0 m³ **8.4 - 9.2 yd³**

WA
600

W
H
E
E
L
L
O
A
D
E
R



Photos may include optional equipment.

WALK-AROUND

Komatsu-integrated design for the best value, reliability, and versatility. Hydraulics, powertrain, frame, and all other major components are engineered by Komatsu. You get a machine whose components are designed to work together for higher production, greater reliability, and more versatility.

High Productivity & Low Fuel Consumption

- High performance SAA6D170E-5 engine
- Low fuel consumption
- Dual-mode engine power select system
- Automatic transmission with shift timing select system
- Lock-up Torque Converter
- Variable displacement piston pump & Closed-center Load Sensing System (CLSS)
- Increased bucket capacity
- Long wheelbase



Harmony with Environment

- EPA Tier 3 and EU stage 3A emissions certified
- Low exterior noise
- Low fuel consumption

NET HORSEPOWER
393 kW 527 HP @ 1800 rpm

OPERATING WEIGHT
53700 - 53900 kg
118,385 - 118,825 lb

BUCKET CAPACITY
6.4 - 7.0 m³ 8.4 - 9.2 yd³

Excellent Operator Environment

- Automatic transmission with ECMV
- Low-noise designed cab
- Electronic controlled transmission lever
- Modulated clutch system
- Engine RPM set system with auto decel
- Electronic Pilot Control levers (EPC)
- Pillar-less large ROPS/FOPS Level 2 integrated cab
- Easy entry/exit, front-hinged door
- Advanced Joystick Steering System (AJSS)

Increased Reliability

- Reliable Komatsu designed and manufactured components
- Sturdy main frame
- Adjustment-free, fully hydraulic, wet disc service and parking brakes
- Hydraulic hoses use flat face O-ring seals
- Sealed DT connectors for electrical connections



Photos may include optional equipment.

Easy Maintenance

- Equipment Management Monitoring System (EMMS)
- Vehicle Health Monitoring System (VHMS)
- Ease of radiator cleaning
- Modular radiator core system

PRODUCTIVITY FEATURES



ecology & economy - technology 3

Komatsu's new "ecot3" engines are designed to deliver optimum performance under the toughest of conditions,

while meeting the latest environmental regulations. This engine is Tier 3 EPA and EU Stage 3A emissions certified; "ecot3" - ecology and economy combine with Komatsu technology to create a high performance engine without sacrificing power or productivity

High Performance SAA6D170E-5 Engine

Electronic Heavy Duty Common Rail fuel injection system provides optimum combustion of fuel. This system also provides fast throttle response to match the machine's powerful tractive effort and fast hydraulic response.

Net: 393 kW **527 HP**

Low Fuel Consumption

The fuel consumption is reduced greatly because of the low-noise, high-torque engine, the large-capacity torque converter with maximum efficiency in the low-speed range, and variable piston pumps for Closed-center Load Sensing System (CLSS).

Dual-Mode Engine Power Select System

This wheel loader offers two selectable operating modes—E and P. The operator can adjust the machine's performance with the selection switch.

- **E Mode:** This mode provides maximum fuel efficiency for general loading.
- **P Mode:** This mode provides maximum power output for hard digging operation or hill climb.



Dual mode engine power selection switch



The eco indicator will help an operator to promote energy saving.

Automatic Transmission with Mode Select System

This operator controlled system allows the operator to select manual shifting or two levels of automatic shifting (low, and high).

Auto L mode is for fuel saving operation with the gear shift timing set at lower speeds than Auto H mode. Therefore Auto L mode keeps the engine in a relatively low rpm range for



Shift mode selection switch

fuel conservation while yielding adequate tractive force by depressing the accelerator pedal.

Lock up clutch switch

Lock-up Torque Converter

The Komatsu designed lock-up torque converter provides increased production efficiency, reduced cycle times and optimum fuel savings in load & carry or hill-climb operations. This optional feature allows the operator to activate the system on/off with a switch located on the right-side control panel.

Variable Displacement Piston Pump and Closed-center Load Sensing System (CLSS)

New design variable displacement piston pump combined with the CLSS delivers hydraulic flow just as the job requires preventing wasted hydraulic pressure. Minimized waste loss contributes to better fuel economy.

- **New Variable Displacement Piston Pump:** The pump delivers only necessary amounts minimizing waste loss.

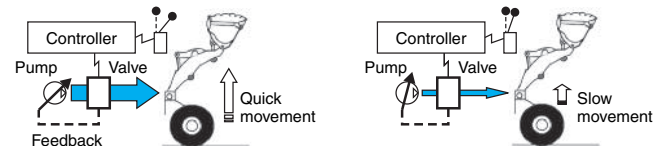

- **Fixed Displacement Piston Pump:** The pump delivers the maximum amount at any time and the unused flow is disposed.

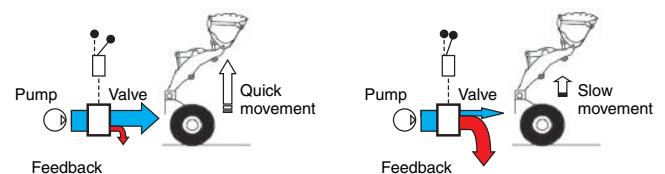



Increased Bucket Capacity Matches With One Class Higher Dump Truck

The WA600 can load 60 ton (70 short ton) trucks with the standard boom. The WA600-3 required an optional high lift boom and 6.4m³ **8.4 yd³** bucket. The WA600-6 maintains good visibility for loading because of increased operator cab height.



Long Wheelbase/Articulation Angle of 43°

The widest tread in class and the long wheelbase provide improved machine stability in both longitudinal and lateral directions. Since the articulation angle is 43°, the operator can work efficiently even in the tightest job sites.

Tread	2650 mm	8'8"
Wheelbase	4500 mm	14'9"
Minimum turning radius (center of outside tire)	7075 mm	23'3"

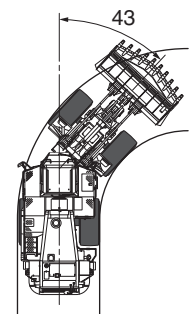

Dumping Clearance: 3995 mm **13'1"**
Dumping Reach: 1800 mm **5'11"**
 (6.4 m³ **8.4 yd³** spade nose bucket with tooth)

INCREASED RELIABILITY

Komatsu Components

Komatsu manufactures the engine, torque converter, transmission, hydraulic units, electric parts, on this wheel loader. Komatsu loaders are manufactured with an integrated production system under a strict quality control system.

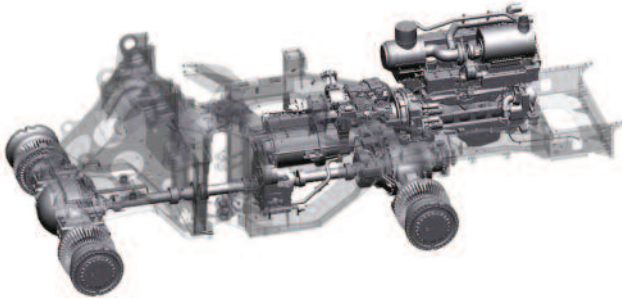

High-rigidity Frames and Loader Linkage

The front and rear frames and the loader linkage have more torsional rigidity to secure resistance against increased stress due to the use of a larger bucket. Frame and loader linkage are designed to accommodate actual working loads, and simulated computer testing proves its strength.



Wet Multi-disc Brakes and Fully Hydraulic Braking System

mean lower maintenance costs and higher reliability. Wet disc brakes are fully sealed. Contaminants are kept out, reducing wear and maintenance. Brakes require no adjustments for wear, meaning even lower maintenance. The new parking brake is also an adjustment-free, wet multi-disc for high reliability and long life.

Added reliability is designed into the braking system by the use of two independent hydraulic circuits. This provides hydraulic backup should one of the circuits fail. Fully hydraulic brakes mean no air system to bleed, or the condensation of water in the system that can lead to contamination, corrosion, and freezing.



Flat Face-to-Face O-Ring Seals

Flat face-to-face O-ring seals are used to securely seal hydraulic hose connections and to prevent oil leakage. In addition, buffer rings are installed to the head side of the all-hydraulic cylinders to lower the load on the rod seals and maximize the reliability.

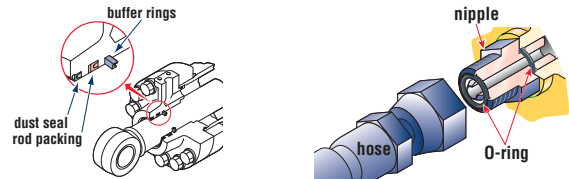

Sealed DT Connectors

Main harnesses and controller connectors are equipped with sealed DT connectors providing high reliability, water resistance and dust resistance.

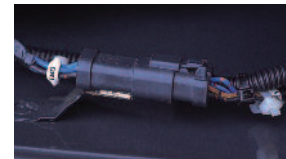

Sweeper Wing (Large Size Tire Guard)

To protect the tire, the WA600 provides a Sweeper Wing on both sides of the bucket.

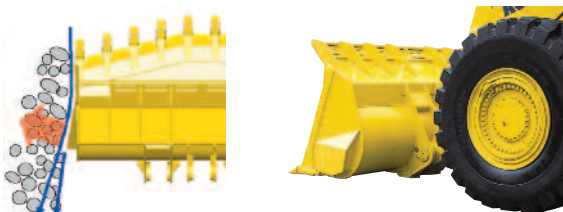

EASY MAINTENANCE



Photo may include optional equipment.

Equipment Management Monitoring System (EMMS)

Monitor is mounted in front of the operator for easy viewing, allowing the operator to easily check gauges and warning lights.



Maintenance Control and Troubleshooting Functions

- **Action code display function:** If an abnormality occurs, the monitor displays action details on the character display at the bottom center of the monitor.
- **Monitor function:** The controller monitors engine oil level, pressure, coolant temperature, air cleaner clogging, etc. If the controller finds abnormalities, the error is displayed on LCD.
- **Replacement time notice function:** Monitor informs replacement time of oil and filters on LCD when replacement intervals are reached.
- **Trouble data memory function:** Monitor stores abnormalities for effective troubleshooting.

Modular Radiator Core System

The modular radiator core is easy to replace without removing the entire radiator assembly.

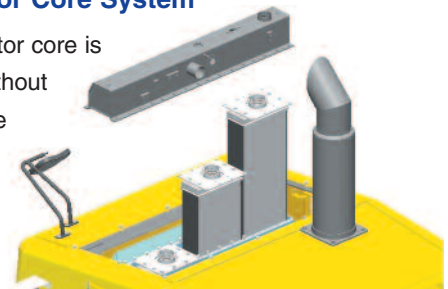

Ease of Radiator Cleaning

If the machine is operating in adverse conditions, the operator can reverse the hydraulic cooling fan from inside the cab by turning a switch on the control panel.



Vehicle Health Monitoring System (VHMS)

VHMS is a management system for large equipment for use in mining, which enables detailed monitoring of fleet via satellite communications. Komatsu and distributors can analyze "vehicle health" and other operating conditions and provide the information to job site using the internet from a remote location on a near-real time basis.

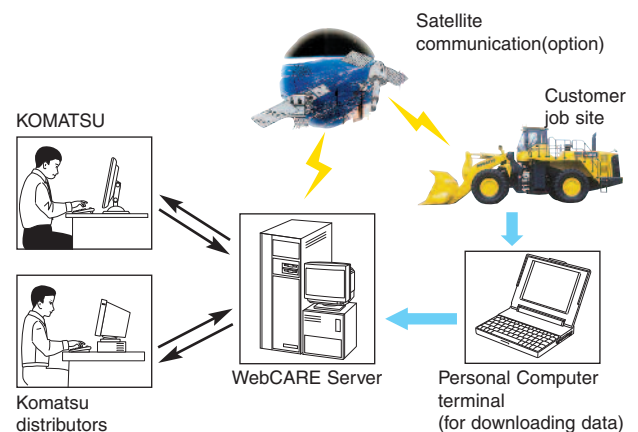

OPERATOR COMFORT

Automatic Transmission with Electronically Controlled Modulation Valve (ECMV)

Automatic transmission with ECMV automatically selects the proper gear speed based on travel speed, engine speed, and other travel conditions. The ECMV system engages the clutch smoothly to prevent lags and shocks when shifting. This system provides efficient machine operation and a comfortable ride.

- **Kick-down**

switch: Consider this valuable feature for added productivity. With the touch of a finger, the kick-down switch

automatically downshifts from second to first when beginning the digging cycle. It automatically upshifts from first to second when the direction control lever is placed in reverse. This results in increased rim pull for better bucket penetration and reduced cycle times for higher productivity.

- **Hold switch:** When auto shift is selected and the operator turns on this switch when the lever is at the 3rd or 4th gear speed position, the transmission is fixed to that gear speed.

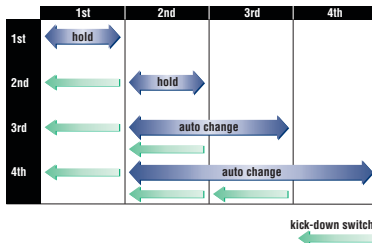

Modulated Clutch System

The Modulated Clutch System controls the tractive effort with left brake pedal from 100% to 20% of the converter output torque.

- Useful for smooth speed reduction when approaching dump trucks for loading.
- Easy control of tire slippage.
- Reduction of shocks in shifting from forward to reverse.

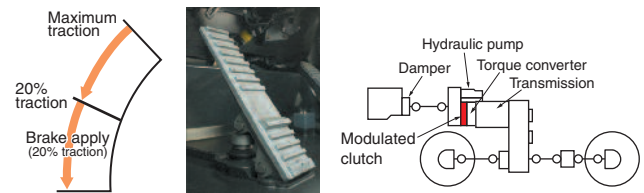

Engine RPM Set System with Auto Decel

Engine Low idle RPM can be easily preset using a push button switch. The system provides auto decel for better fuel consumption.



- 1: ECSS
- 2: Remote Boom positioner switch
- 3: Remote bucket digging angle control switch
- 4: RPM set (On/Off)
- 5: RPM idle set
- 6: Semi-auto digging system
- 7: Boom control
- 8: Bucket control

Comfortable Operation

Electronic Pilot Control (EPC) levers

The finger control EPC work equipment levers have light operating effort and short stroke facilitating easy operation. The operator's comfort is further increased by the full large size adjustable arm rests. Combined with CLSS, this system allows the following new functions for easy and efficient operation:

- **Remote Boom Positioner with shockless stop function:** The highest and lowest position of the bucket can be set from cab to match any truck body. Once the positioner is set, the bucket is smoothly stopped at desired position with no shock.
- **Remote bucket digging angle control:** The digging bucket angle can be easily set from cab to match of ground condition.
- **Semi-auto digging system:** Bucket tilt operation can be automatically done when digging.

Advanced Joystick Steering System (AJSS)

AJSS is a feedback steering system which has been incorporated to allow steering and forward and reverse selection to be controlled by wrist and finger control. With the feedback function added, the machine steering angle is defined exactly the same angle as the lever tilt angle.

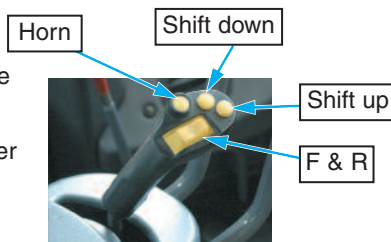

Low-noise Design

Noise at operator's ear noise level : 73 dB(A)
Dynamic noise level (outside): 113 dB(A)

The large cab is mounted with Komatsu's unique ROPS/FOPS Level 2 viscous mounts. The low-noise engine, hydraulically driven fan, and hydraulic pumps are mounted with rubber cushions, and the cab sealing is improved to provide a quiet, low-vibration, dustproof pressurized, and comfortable operating environment. Also, exterior noise is lowest in this class.

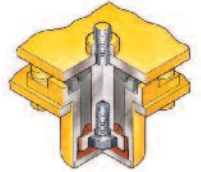

Pillar-less Large Cab

A wide pillar-less flat glass provides excellent front visibility. The wiper arm covers a large area to provide great visibility even on rainy days.

The cab area is the largest in its class providing maximum space for the operator.

Rear Access Stairs

For the purpose of easily boarding and exiting the machine, rear access stairs with handrails are provided.

The step width, clearance, and the step angle have been designed for safety climbing both up and down. A step light provides light for night boarding.



SPECIFICATIONS



ENGINE

Model Komatsu SAA6D170E-5
 Type Water-cooled, 4-cycle
 Aspiration Turbocharged, aftercooled, cooled EGR
 Number of cylinders 6
 Bore x stroke 170 mm x 170 mm **6.69" x 6.69"**
 Piston displacement 23.15 ltr **1413 in³**
 Governor all-speed, electronic
 Horsepower
 SAE J1995 Gross 396 kW **530 HP**
 ISO 9249/SAE J1349 Net 393 kW **527 HP**
 Hydraulic fan at maximum speed Net 374 kW **502 HP**
 Rated rpm 1800 rpm
 Fan drive method for radiator cooling Hydraulic
 Fuel system Direct injection
 Lubrication system:
 Method Gear pump, force-lubrication
 Filter Full-flow type
 Air cleaner Dry type with double elements and
 dust evacuator, plus dust indicator
 EPA Tier 3 and EU stage 3A emissions certified.



TRANSMISSION

Torque converter:
 Type 3-element, single-stage, double-phase
 Transmission:
 Type Full-powershift, planetary type
 Travel speed: km/h **mph**
 Measured with 35/65-33 tires

() : Look-up clutch ON

	1st	2nd	3rd	4th
Forward	6.7 4.2	11.7 7.3	20.3 12.6	33.8 21.0
	—	(12.4 7.7)	(21.7 13.5)	(37.7 23.4)
Reverse	7.3 4.5	12.8 8.0	22.0 13.7	37.0 23.0



AXLES AND FINAL DRIVES

Drive system Four-wheel drive
 Front Fixed, full-floating
 Rear Center-pin support, full-floating,
 26° total oscillation
 Reduction gear Spiral bevel gear
 Differential gear Conventional type
 Final reduction gear Planetary gear, single reduction



BRAKES

Service brakes Hydraulically actuated,
 wet disc brakes actuate on four wheels
 Parking brake Wet disc brake
 Emergency brake Parking brake is commonly used



STEERING SYSTEM

Type Articulated type, full-hydraulic power steering
 Steering angle 43° each direction
 Minimum turning radius at
 the center of outside tire 7075 mm **23'3"**



HYDRAULIC SYSTEM

Steering system:
 Hydraulic pump Piston pump
 Capacity 163 ltr/min **43.1 U.S. gal/min** at rated rpm
 Relief valve setting 34.3 MPa 350 kgf/cm² **4,980 psi**
 Hydraulic cylinders:
 Type Double-acting, piston type
 Number of cylinders 2
 Bore x stroke 115 mm x 510 mm **4.5" x 20"**
 Loader control:
 Hydraulic pump Piston pump
 Capacity 239 + 239 ltr/min **63.1 + 63.1 U.S. gal/min**
 at rated rpm
 Relief valve setting 34.3 MPa 350 kgf/cm² **4,980 psi**
 Hydraulic cylinders:
 Type Double-acting, piston type
 Number of cylinders—bore x stroke:
 Boom cylinder 2- 200 mm x 1067 mm **7.9" x 42"**
 Bucket cylinder 1- 225 mm x 776 mm **8.9" x 30.6"**
 Control valve 2-spool type
 Control positions:
 Boom Raise, hold, lower, and float
 Bucket Tilt-back, hold, and dump
 Hydraulic cycle time (rated load in bucket)
 Raise 9.3 sec
 Dump 2.3 sec
 Lower (Empty) 4.1 sec



SERVICE REFILL CAPACITIES

Cooling system 147 ltr **38.8 U.S. gal**
 Fuel tank 718 ltr **189.7 U.S. gal**
 Engine 86 ltr **22.7 U.S. gal**
 Hydraulic system 443 ltr **117.0 U.S. gal**
 Axle (each front and rear) 155 ltr **41.0 U.S. gal**
 Torque converter and transmission 83 ltr **21.9 U.S. gal**



DIMENSIONS

3990 mm 13'1" boom, 35/65-33-36PR(L-4) tires.

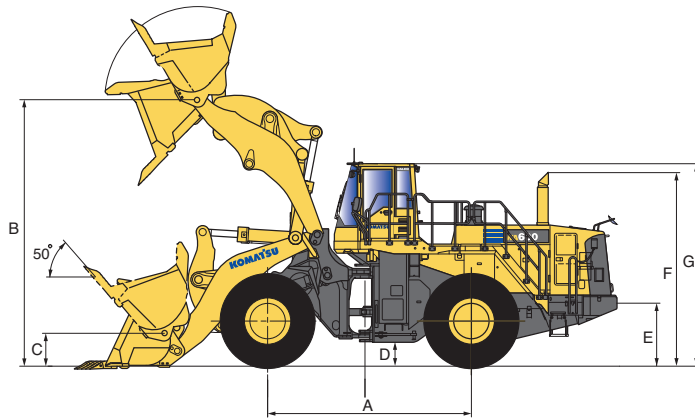

		3990 mm 13'1" Boom
	Tread	2650 mm 8'8"
	Width over tires	3540 mm 11'7"
A	Wheelbase	4500 mm 14'9"
B	Hinge pin height, max. height	5885 mm 19'4"
C	Hinge pin height, carry position	720 mm 2'4"
D	Ground clearance	525 mm 1'9"
E	Hitch height	1385 mm 4'7"
F	Overall height, top of the stack	4270 mm 14'0"
G	Overall height, ROPS Level 2 cab	4460 mm 14'8"

	Excavating Bucket	Excavating Bucket	Excavating Bucket	Stock Pile Bucket
	Spade Nose Teeth and WSE*1	Straight Edge Teeth and BSE*2	Straight Edge BOCE	Spade Nose Teeth and WSE*1
*1 Weld-on segment edges *2 Bolt-on segment edges				
Bucket capacity	heaped 6.4 m ³ 8.4 yd³ struck 5.3 m ³ 6.9 yd³	6.5 m ³ 8.5 yd³ 5.4 m ³ 7.1 yd³	6.5 m ³ 8.5 yd³ 5.4 m ³ 7.1 yd³	7.0 m ³ 9.2 yd³ 5.8 m ³ 7.6 yd³
Bucket width	3685 mm 12'1"	3685 mm 12'1"	3685 mm 12'1"	3685 mm 12'1"
Bucket weight	5115 kg 11,280 lb	5020 kg 11,070 lb	4745 kg 10,460 lb	5265 kg 11,610 lb
Dumping clearance, max. height and 45° dump angle	3995 mm 13'1"	4180 mm 13'9"	4365 mm 14'4"	3945 mm 12'11"
Reach at max. height and 45° dump angle	1800 mm 5'11"	1610 mm 5'3"	1460 mm 4'9"	1850 mm 6'1"
Reach at 2130 mm (7') clearance and 45° dump angle	3015 mm 9'11"	2875 mm 9'5"	2765 mm 9'1"	3050 mm 10'0"
Reach with arm horizontal and bucket level	4135 mm 13'7"	3870 mm 12'8"	3630 mm 11'11"	4205 mm 13'10"
Operating height (fully raised)	7925 mm 26'0"	7925 mm 26'0"	7925 mm 26'0"	7995 mm 26'3"
Overall length	11985 mm 39'4"	11725 mm 36'6"	11480 mm 37'8"	12055 mm 39'7"
Loader clearance circle (bucket at carry, outside corner of bucket)	17000 mm 55'9"	17060 mm 56'0"	16900 mm 55'5"	17040 mm 55'11"
Digging depth	0° 130 mm 5.1" 10° 515 mm 1'8"	135 mm 5.3" 480 mm 1'7"	105 mm 4.1" 410 mm 1'4"	130 mm 5.1" 530 mm 1'9"
Static tipping load	straight 36580 kg 80,645 lb 43° full turn 30485 kg 67,200 lb	36960 kg 81,485 lb 30865 kg 68,040 lb	36950 kg 81,455 lb 30855 kg 68,020 lb	36440 kg 80,335 lb 30345 kg 66,890 lb
Breakout force	388 kN 39570 kgf 87,230 lb	448 kN 45685 kgf 100,720 lb	447 kN 45580 kgf 100,490 lb	375 kN 38240 kgf 84,300 lb
Operating weight	53700 kg 118,385 lb	53600 kg 118,165 lb	53330 kg 117,575 lb	53840 kg 118,695 lb

All dimensions, weights, and performance values based on SAE J732c and J742b standards.

Static tipping load and operating weight shown include lubricant, coolant, full fuel tank, ROPS Level 2 cab, and operator.

Machine stability and operating weight affected by tire size and other attachments.

Bucket Selection Guide

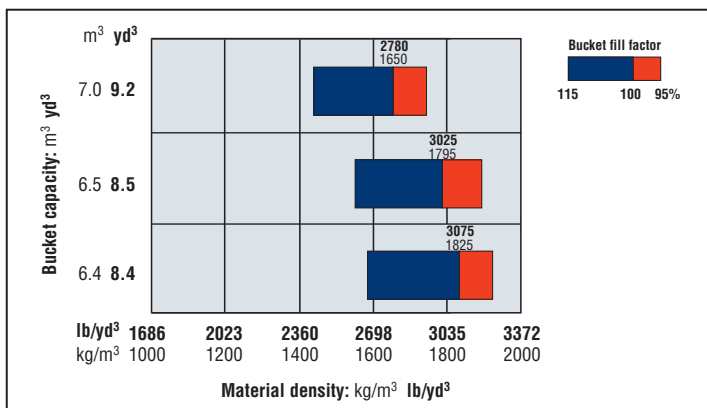



DIMENSIONS

3850 mm 12'8" boom, 35/65-33-36PR(L-4) tires.

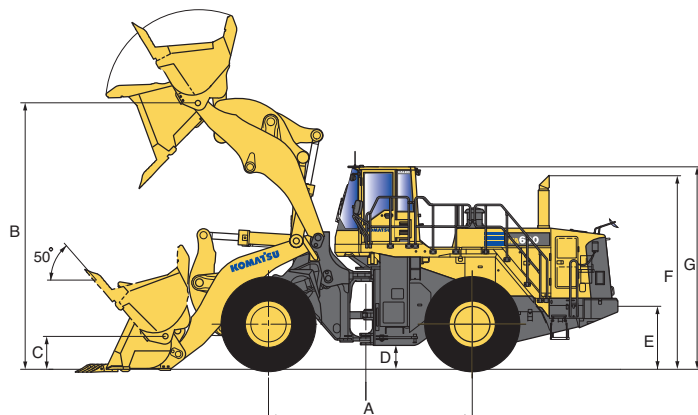

		3850 mm 12'8" Boom
	Tread	2650 mm 8'8"
	Width over tires	3540 mm 11'7"
A	Wheelbase	4500 mm 14'9"
B	Hinge pin height, max. height	5665 mm 18'7"
C	Hinge pin height, carry position	670 mm 2'2"
D	Ground clearance	525 mm 1'9"
E	Hitch height	1385 mm 4'7"
F	Overall height, top of the stack	4270 mm 14'0"
G	Overall height, ROPS Level 2 cab	4460 mm 14'8"

	Excavating Bucket	Excavating Bucket	Excavating Bucket
	Spade Nose Teeth and WSE*1	Straight Edge Teeth and BSE*2	Straight Edge BOCE
*1 Weld-on segment edges *2 Bolt-on segment edges			
Bucket capacity	heaped 7.0 m ³ 9.2 yd ³	7.0 m ³ 9.2 yd ³	7.0 m ³ 9.2 yd ³
	struck 5.8 m ³ 7.6 yd ³	5.8 m ³ 7.6 yd ³	5.8 m ³ 7.6 yd ³
Bucket width	3685 mm 12'1"	3685 mm 12'1"	3685 mm 12'1"
Bucket weight	5265 kg 11,610 lb	4865 kg 10,725 lb	4875 kg 10,750 lb
Dumping clearance, max. height and 45° dump angle	3730 mm 12'3"	3905 mm 12'10"	4105 mm 13'6"
Reach at max. height and 45° dump angle	1885 mm 6'2"	1690 mm 5'7"	1550 mm 5'1"
Reach at 2130 mm (7') clearance and 45° dump angle	2900 mm 9'6"	2775 mm 9'1"	2670 mm 8'9"
Reach with arm horizontal and bucket level	4065 mm 13'4"	3800 mm 12'6"	3560 mm 11'8"
Operating height (fully raised)	7775 mm 25'6"	7775 mm 25'6"	7775 mm 25'6"
Overall length	11870 mm 38'11"	11610 mm 38'1"	11370 mm 37'4"
Loader clearance circle (bucket at carry, outside corner of bucket)	16875 mm 55'4"	16920 mm 55'6"	16765 mm 55'0"
Digging depth	0° 130 mm 5.1"	140 mm 5.5"	100 mm 3.9"
	10° 530 mm 1'9"	495 mm 1'7"	410 mm 1'4"
Static tipping load	straight 37880 kg 83,505 lb	38260 kg 84,345 lb	38250 kg 84,325 lb
	43° full turn 31565 kg 69,595 lb	31945 kg 70,425 lb	31935 kg 70,405 lb
Breakout force	378 kN 38550 kgf 84,980 lb	433 kN 44150 kgf 97,340 lb	432 kN 44050 kgf 97,120 lb
Operating weight	53900 kg 118,825 lb	53500 kg 117,945 lb	53500 kg 117,945 lb

All dimensions, weights, and performance values based on SAE J732c and J742b standards. Static tipping load and operating weight shown include lubricant, coolant, full fuel tank, ROPS Level 2 cab, and operator.

Machine stability and operating weight affected by tire size and other attachments.

Bucket Selection Guide

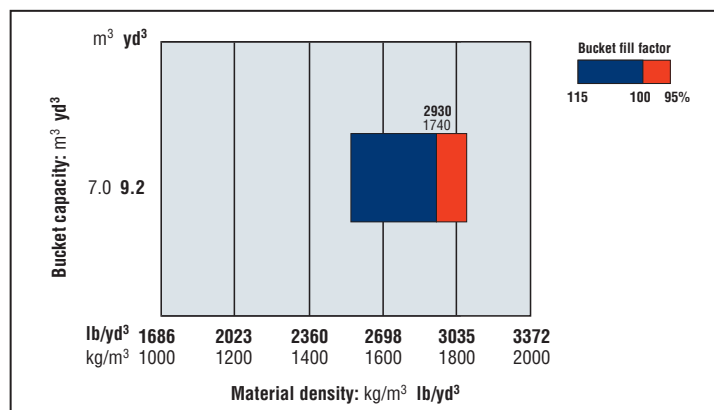

LOAD & CARRY SPECS

3850 mm 12'8" boom, 35/65-R33 2 Stars (L-4) BS tires

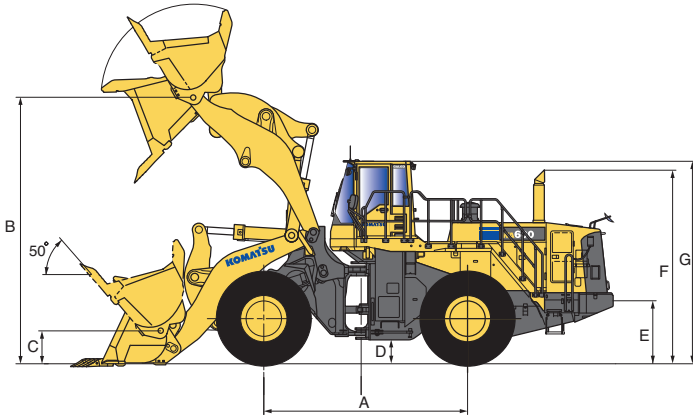

	3850 mm 12'8" Boom
Tread	2650 mm 8'8"
Width over tires	3555 mm 11'8"
A Wheelbase	4500 mm 14'9"
B Hinge pin height, max. height	5665 mm 18'7"
C Hinge pin height, carry position	670 mm 2'2"
D Ground clearance	525 mm 1'9"
E Hitch height	1385 mm 4'7"
F Overall height, top of the stack	4270 mm 14'0"
G Overall height, ROPS Level 2 cab	4460 mm 14'8"

		Load & Carry Bucket
*1 Weld-on segment edges		Spade Nose Teeth and WSE*1
Bucket capacity	heaped	7.8 m ³ 10.2 yd ³
	struck	6.6 m ³ 8.6 yd ³
Bucket width		3685 mm 12'1"
Bucket weight		5485 kg 12,092 lb
Dumping clearance, max. height and 45° dump angle		3645 mm 12'0"
Reach at max. height and 45° dump angle		1965 mm 6'5"
Reach at 2130 mm (7') clearance and 45° dump angle		2955 mm 9'8"
Reach with arm horizontal and bucket level		4185 mm 13'9"
Operating height (fully raised)		7900 mm 25'11"
Overall length		11990 mm 39'4"
Loader clearance circle (bucket at carry, outside corner of bucket)		16940 mm 55'7"
Digging depth	0°	130 mm 5.1"
	10°	550 mm 1'10"
Static tipping load	straight	43700 kg 96,342 lb
	43° full turn	36300 kg 80,028 lb
Breakout force		355 kN 36200 kgf 79,807 lb
Operating weight		56400 kg 124,341 lb

All dimensions, weights, and performance values based on SAE J732c and J742b standards.

Static tipping load and operating weight shown include lubricant, coolant, full fuel tank, ROPS Level 2 cab, and operator. Machine stability and operating weight affected by tire size and other attachments.

Bucket Selection Guide

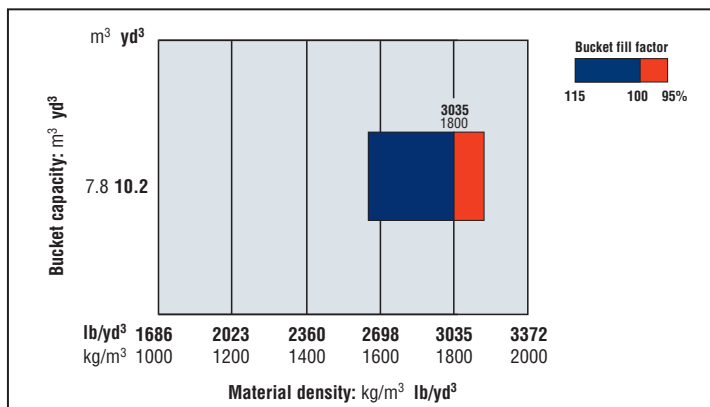



STANDARD EQUIPMENT

- 2-spool valve for boom and bucket controls
- 3990 mm **13'1" boom**
- Advanced Joystick Steering System (AJSS)
- Alternator, 90 A/24 V
- AM/FM stereo radio cassette
- Auto air conditioner
- Auto shift transmission with mode select system
- Back-up alarm
- Back-up lamp
- Battery disconnect switch
- Batteries, 200 Ah/12 V x 2
- Boom kick-out
- Bucket positioner
- Counterweight, large 3780 kg **8,333 lb**
- Directional signal
- Electronically Controlled Suspension System (ECSS)
- Engine RPM set
- Engine, Komatsu SAA6D170E-5 diesel
- EPC fingertip control levers with automatic leveler and positioner
- Floormat
- Front fender
- Hard water arrangement (corrosion resister)
- Hydraulic-driven fan with reverse rotation
- In-line filter, steering
- In-line filter, high pressure hydraulic
- Lift cylinders and bucket cylinder
- Lock-up clutch torque converter
- Main monitor panel with Equipment Management Monitoring System (EMMS)
- Radiator mask, lattice type
- Rear access stairs
- Rear defroster (electric)
- Rear under view mirror
- Rearview mirrors
- Rear window washer and wiper
- Rims for 35/65-R33 L4 tires
- ROPS/FOPS Level 2 cab
- Seat belt, 76 mm **3" wide**
- Seat, suspension type with reclining
- Semi-auto digging system
- Service brakes, wet disc type
- Starting motor, 11.0 kW/24 V x 2
- Sun visor
- Transmission, 4 forward and 4 reverse
- Vehicle Health Monitoring System (VHMS)



OPTIONAL EQUIPMENT

- 3850 mm **12'8" boom**
- Brake cooling system
- Bucket, excavating spade nose w/teeth- 6.4 m³ **8.4 yd³**
- Bucket, excavating spade nose w/teeth- 7.0 m³ **9.2 yd³**
- Bucket, excavating straight edge w/teeth- 6.5 m³ **8.5 yd³**
- Bucket, excavating straight edge w/teeth- 7.0 m³ **9.2 yd³**
- Bucket, excavating straight edge w/BOCE- 6.5 m³ **8.5 yd³**
- Bucket, excavating straight edge w/BOCE- 7.0 m³ **9.2 yd³**
- Bucket, stock pile, spade nose w/teeth- 7.0 m³ **9.2 yd³**
- Bucket, load & carry, spade nose w/teeth- 7.8 m³ **10.2 yd³**
- Emergency steering (SAE)
- Limited slip differential (F&R)
- Load & carry spec arrangement
- Power train underguard
- Rear fender



ALLIED ATTACHMENTS

- Loadrite weighing system, L2180 Model
- Loadrite weighing system, 2180 Model with Material Management System
- Loadrite weighing system, LP950 printer

AESS716-04

©2012 Komatsu America Corp.

Printed in USA

K2(3M)C

2/12 (EV-1)

KOMATSU®



www.KomatsuAmerica.com



Komatsu America Corp. is an authorized licensee of Komatsu Ltd. Materials and specifications are subject to change without notice **KOMATSU** is a registered trademark of Komatsu Ltd., Japan